



# Surveillance Cameras (cctv)

## Working with 3D printed material:

The 3D material used is brittle and may break. Take care in removing parts from the frame. Some parts have been hollowed out to reduce printing costs. Holes are placed out of site but can be filled with modeling putty or plastic sheet.

3D printing of this conversion set was done in a special resin bath. Due to the production method a wax residue can remain on the parts. Cleaning them is not difficult but necessary: Remove parts from the frame and clean them thoroughly using a soft brush and water and dishwashing fluid. It is also possible to use an ultrasonic cleaner with water. Redo cleaning process until water remains clear. A heavier cleaning can be done with white spirit or alcohol.

Use enamel based paint for the first paint layer. This seals any 3D printing residue that might be left from the printing process. When left unpainted the 3D material may start to 'sweat' and cleaning must be redone.

NOTE: discoloration will occur to uncleaned and/or unpainted parts. This will NOT influence the material quality.

## Parts:

- 1 - Camera (4x)
- 2 - Camera swivelmount (4x)
- 3 - Camera wallmount (2x)
- 4 - Ballcamera 1 mount
- 5 - Ballcamera 1 dome
- 6 - Ballcamera 1
- 7 - Ballcamera 2 mount
- 8 - Ballcamera 2 dome
- 9 - Ballcamera 2
- 10 - Camera stand
- 11 - Loudspeaker
- 12 - Camera stand door

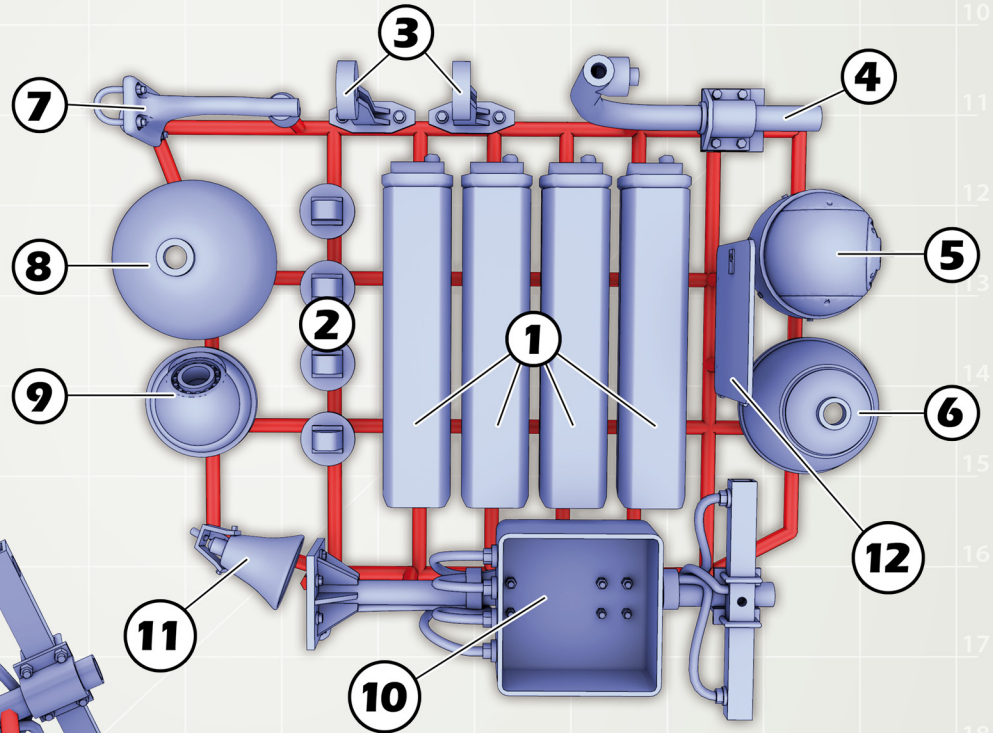

To remove parts, please cut the red parts.

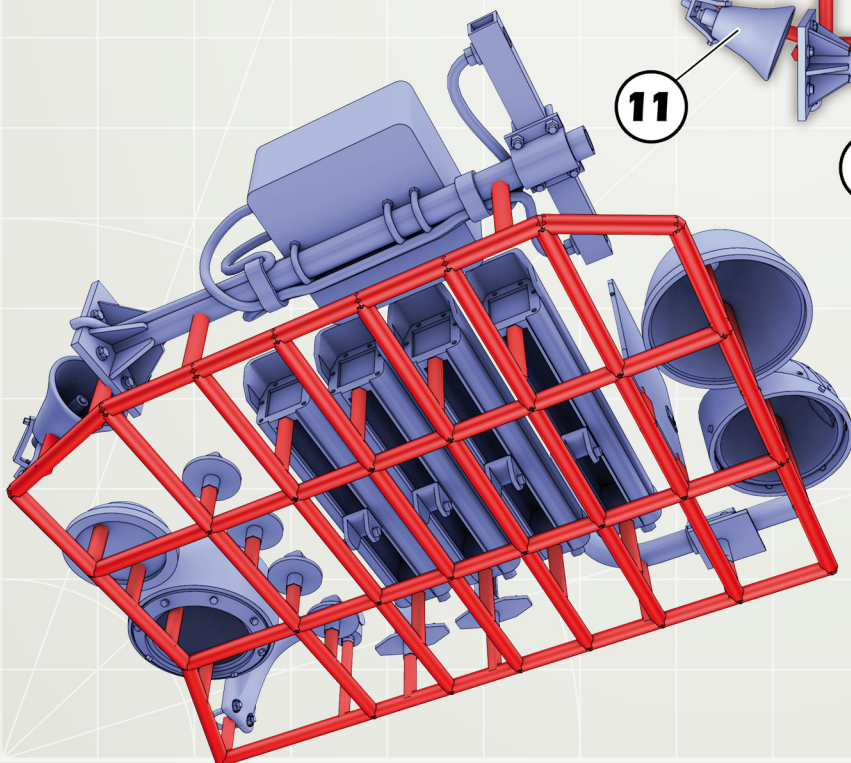

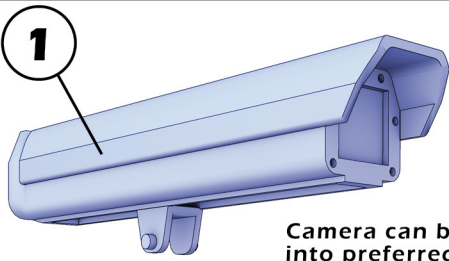

Camera can be rotated into preferred position

**2x**

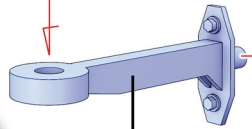

drill hole in fixing-position for better grip (1mm)

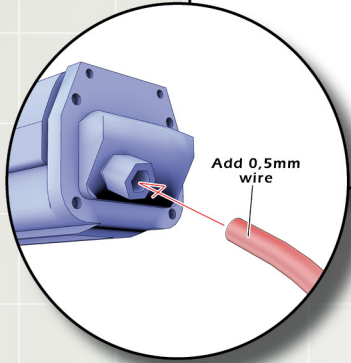

Add 0,5mm wire

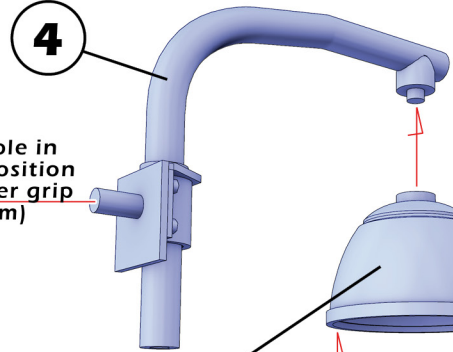

drill hole in fixing-position for better grip (1mm)

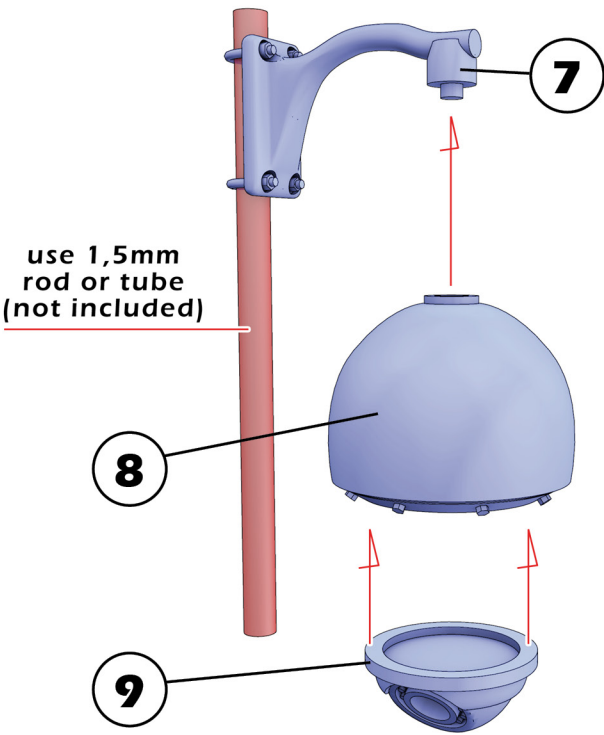
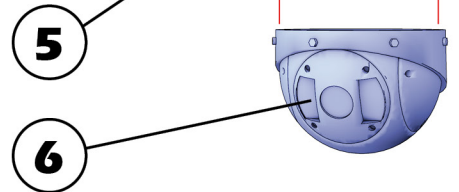

use 1,5mm rod or tube (not included)

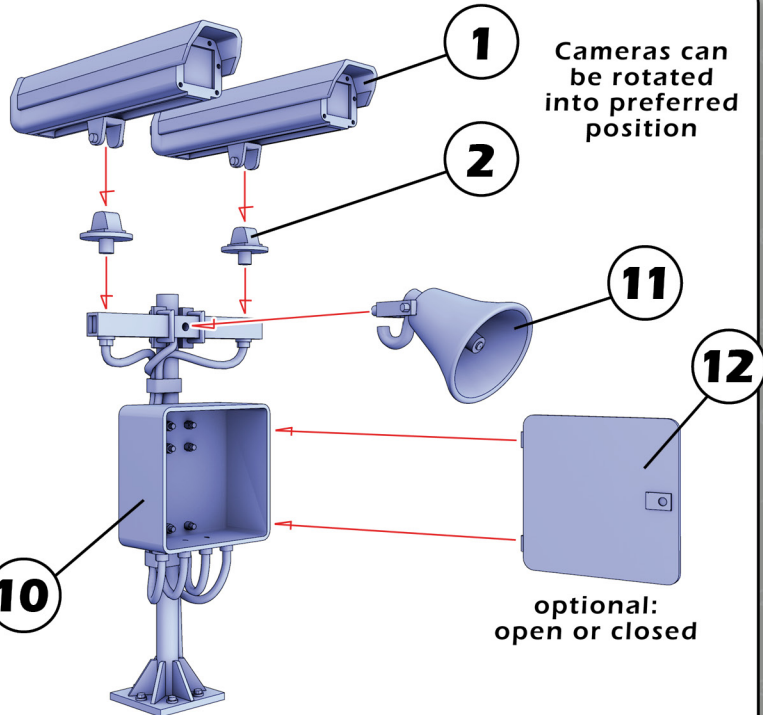
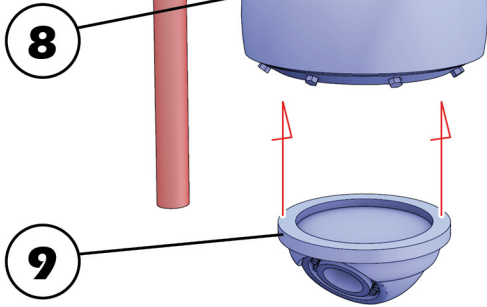

Cameras can be rotated into preferred position

optional: open or closed

